

# SELF - PROPELLED SUCTION STREET SWEEPER *ANTOLI 400 L.*

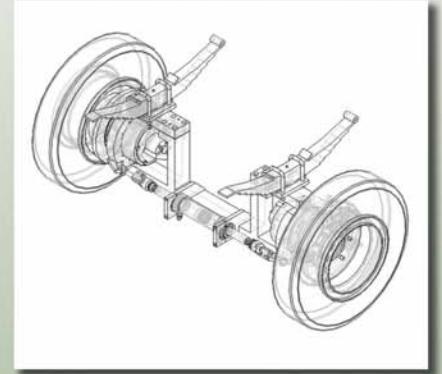

# SELF - PROPELLER SUCTION STREET AWEEPER *ANTOLI 400 L.*



## DESING



## MANUFACTURE

Informe nº: 88-BV1423-0007 Pág. 1 de 1

AGENCIA DE: INSPECCIÓN Y APROBACIÓN PARA VEHÍCULOS FABRICADOS PARA USOS ESPECÍFICOS NO AUTOMÓVILES

4. SOLICITANTE Y VEHÍCULO

1.1 SOLICITANTE:	BARREDORAS ANTOLI S.L.
1.2 VEHÍCULO:	ANTOLI
TÍPOLOGÍA:	400
Nº DE BASTIDOR INSPECCIONADO:	40000001
CATEGORÍA:	BARREDORAS AUTOPROPULSADAS
NOMBRE Y DIRECCIÓN DEL FABRICANTE:	BARREDORAS ANTOLI S.L. Pol. Ind. Estrella - Bazaú - Paredes - SA - 14400 POBLACIÓN: CALZADILLA

OTROS NÚMEROS DE BASTIDOR (CLIENTES POR ESTE INFORME): 40000016 - 40000017 - 40000018 - 40000019 - 40000020 - 40000021 - 40000022

Se declara que el fabricante o representante del vehículo identificado con estos datos de bastidor, con identidad al vehículo inspeccionado.

6. CONCLUSIONES DEL INFORME

El vehículo objeto de esta inspección cumple con los requisitos establecidos para este tipo de vehículos conforme se detalla en el punto 7 del Anexo 9 del RD 1033/2009, para sus vehículos matricados en el territorio de España.

Los datos de identificación del vehículo no coinciden con los datos de fabricación, modelo y versión que aparecen en el Catálogo de Vehículos (2 páginas) de la Dirección General de Tráfico.

Fecha: Este vehículo: 27/04/2014

El jefe del Laboratorio: Juan Manuel Segura Aguilera

El jefe del Área: Juan Manuel Prieto Barea

NOTA: Tiempo de Análisis: 20-41 minutos



## QUALITY

## MAINTENANCE



## PRESENTATION:

In its 2nd Generation, the new street sweeper Suction Antoli model 400 L EU5, is reaffirmed as the most versatile, cost effective and powerful on the market.

With two steering axles has great maneuverability and small turning radius. Its large capacity lets you work all day without need to stop to empty the large hopper. Its powerful suction system and ease of handling of the system scanning allows one-pass sweeping any kind of way. In this 2nd generation the cabin has been redesigned to take full and complete visibility of the scanning area. We have also thought of the Environment, riding on the new sweeper Antoli 400 L EURO 5 engine more powerful and more ecological.



## HOPPER DUMPING:

Drains the waste by hydraulic tipping system, adapted for hopper dumping on standardized containers.

Hopper Dumping height: 900 mm.

Optional:  
Elevated Hopper Dumpin: 1.600 mm.



## LARGE CAPACITY:

Its 4.200 litres of capacity to make this sweeper best complement make it an ideal team for the big city, as its high performance place it among the highest in its range, allowing a saving in maintenance cost.



## INSIDE:

Wide area and comfortable inside with excellent visibility through the large glass front and side. With adjustable tilt steering wheel, comfortable and versatile, easy to drive despite its large dimensions.

**Technical Features****ANTOLI 400 L. Euro 5.****Features and Weight**

Length / width / height.	4.900 / 1.800 / 2.650 mm
Distance between axles.	1.850 mm
TARA / MMA / Payload.	5.000 / 9.500 / 4.500 Kg.

**Engine.**

Mark / Model.	VM / R756 EU5. Common Rail.
Cylinder Capacity / N° of Cylinders.	4.455 cm <sup>3</sup> / 6 in line.
Power.	115 Kw - 156 CV @ 2.600 rpm
Fuel.	Diesel
Emissions Regulations.	EURO 5. Stage IIIB.

**Transmission.**

Type/ Traction.	Hydrostatic 2 Speed. / to 4 wheels with independent engines.
Speed: Work / Displacement.	From 0 to 20 Km/h / From 0 to 40 Km/h.
Maximum slope.	25%.

**Brake System.**

Service and Emergency.	Hydrostatic 4-wheel, and hydraulic servo drum brake pedal and the front wheels.
Hand Brake.	By means of electrical switch operating negative brake to back wheels.

**Chassis and Steering.**

Chassis.	Rigid structural tube made of ST-52.
Steering / Turning Radius.	Hydraulics and assisted to 4 wheels / Inside Turning Radius: 2,00 m.

**Axes, Suspension and Tires.**

Front / Back.	2 Driving and directional wheels / 2 Driving and directional wheels.
Suspension.	Shock absorber and spring, independent axis. Stabilizer bar on the rear axle.
Tires.	8.25 - 15. 18 PR.

**Electric System / Illumination.**

Battery / Alternator.	2 of 12 V 100 Ah / 24 V 120 A.
Illumination.	Conforms to highways regulations.

**Sweep System.**

Aspiration.	High-performance turbine, adjustable from 1.500 to 2.600 rpm.
Floating Mouthpiece.	Flap for bulky waste. Width 950 mm.
Suction Pipe.	In stainless steel. Positioned to favor straight suction. Ø 220 mm.
Performance of work approximately	32.000 m <sup>2</sup> /h.
Automatic Central Lubrication for all lubrication of the machine.	

**Brushes.**

Quantity / Size / Speed.	2 standard side brushes / Ø 900 mm / 0 to 200 rpm.
Brushes mobility.	By Joystick with independent mobility.
Safety.	Floating and retractable brush to impact.
Sweep width.	From 1.800 to 2.500 mm.

**Hopper.**

Hopper / Capacity.	Stainless Steel / 4.200 liters capacity.
Dumping / Discharge	Hydraulic tilt and lift the rear / Height 0.90 m.
Safety.	Provides emergency manual lift.

**Water and Irrigation System.**

Tanks / Capacity.	Steel cut / 600 liters of clean water.
Water Recycling.	Recycling system with at least 300 liters of water.
Irrigation.	By electric pump for broadcasters brushes.
Spear gun with 15 m hose and reel machine. Pressure: 0-125 bar. Flow: 15 liters / min.	

**Cabin.**

Cabin.	Comfortable suspension. Acoustic and thermal insulation.
Places.	2-3 seats approved. Driver seat with air suspension.
Visibility / Mirrors.	Large glass area and total visibility of the brushes / 2 retractable.
Comfort.	Integrated Air Conditioning and Heating. Adjustable steering wheel. Radio Cd.
Instrumentation.	Ergonomically positioned and optimum performance and visibility to the operator. Touch screen 7 "Can Bus Interface and rear view camera.

**Optional Equipment.**

Dump height to 1.60 m high. Third front brush extensible. Flushing Team 2 rotating poles. Salt spreader of 12-24 V. Front snow plow. Front hydraulic outlets for other equipment.	
---	--

**It fulfills safety norms 89/392 CEE. (Safety in machines)**

This catalogue is not contractual. Subject to change without notice. We accept no responsibility for errors or omissions.

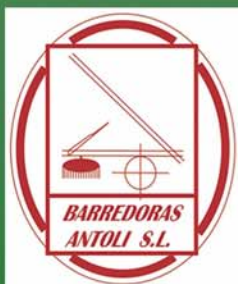

## **BARREDORAS ANTOLI S.L.**

Polg. Ind. Dehesa Boyal, N° 5-8.

Apartado Correos N° 49.

14400 - POZOBLANCO (Córdoba) ESPAÑA.

Teléfono +34 957 770 439 Fax (+34) 957 770 491.

Web: [www.barredorasantoli.com](http://www.barredorasantoli.com)

E-mail: [barredorasantoli@telefonica.net](mailto:barredorasantoli@telefonica.net)

